

High Performance Cantilever Gate Hardware

Accommodates
4400 lbs at 65ft opening
7000 lbs at 30ft opening

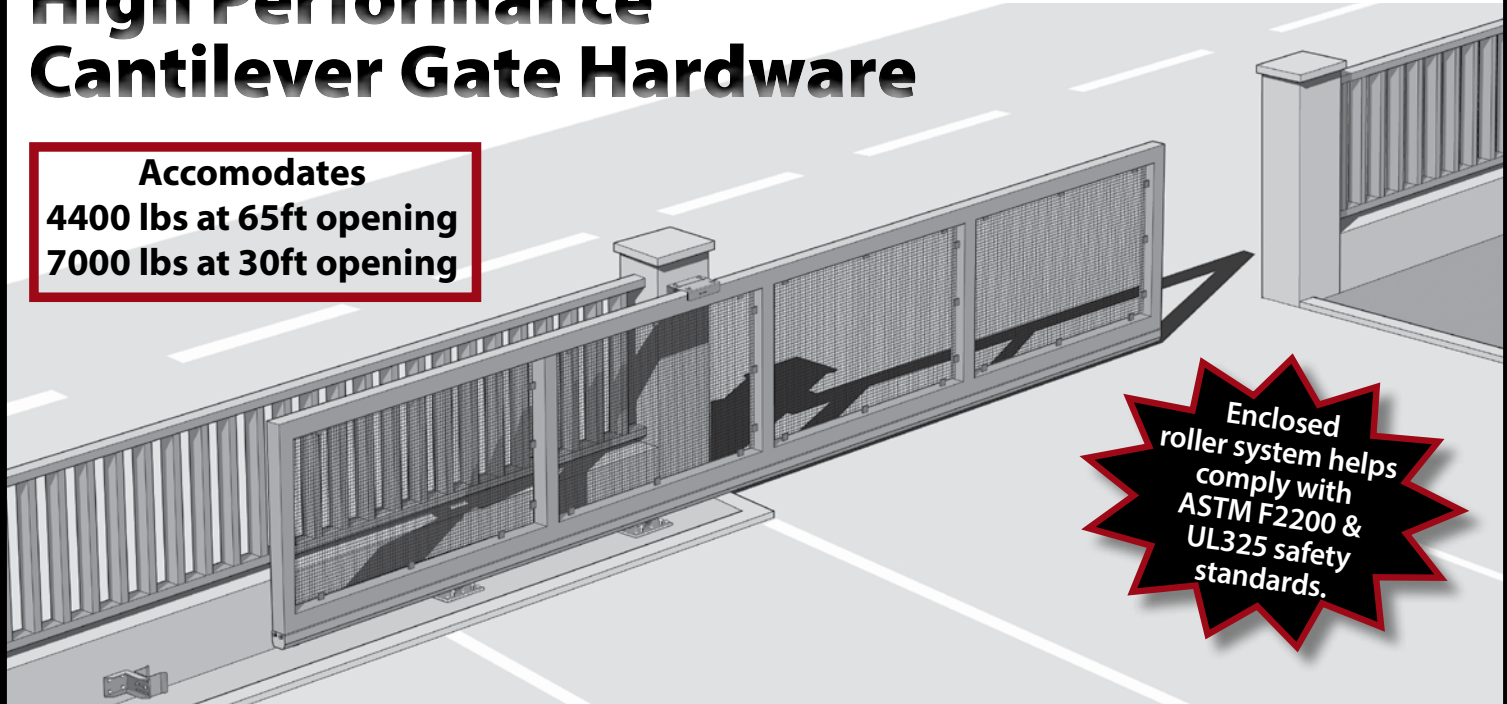

Enclosed roller system helps comply with ASTM F2200 & UL325 safety standards.

Product Manual

TABLE OF CONTENTS

ABOUT THE SYSTEM	2
FREQUENTLY ASKED QUESTIONS	3
GATE DESIGN & SITE CONSIDERATIONS.....	4-9
INSTALLATION INSTRUCTIONS	10-15
TIPS & HINTS	16-18



Manufactured in Italy by
COMUNELLO
LIFE MADE EASY

Duragates cantilever gate hardware offers a trouble free and easy to install solution for sliding gates!

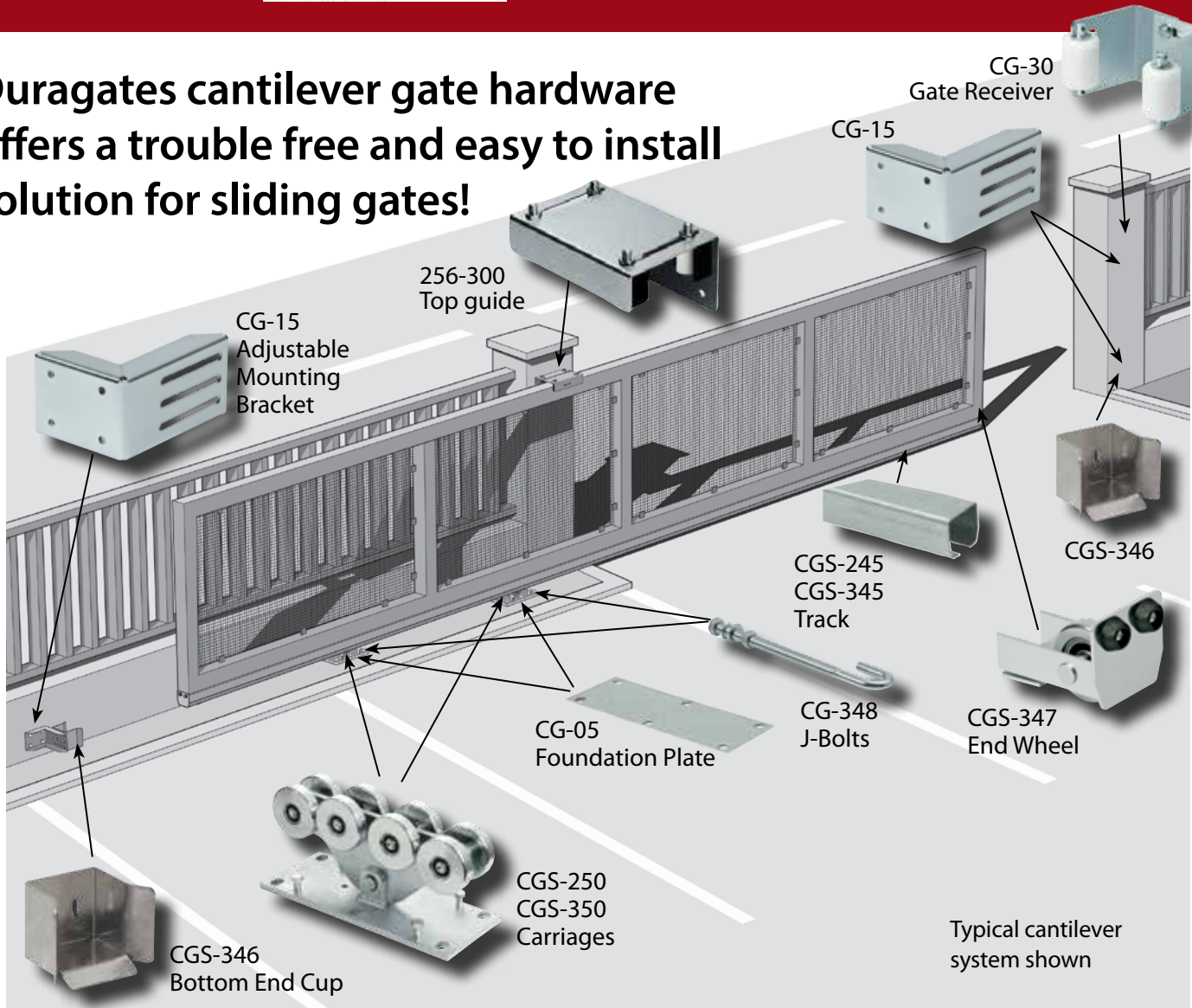

This simple, yet heavy duty system can handle almost all sliding gate applications. Sealed bearings and covered rollers avoid many of the usual maintenance and efficiency problems due to weather elements. They also help comply with UL325 and ASTM F2200 gate safety standards.

All products are manufactured in Italy by Fratelli Comunello, the world leaders in gate hardware. The technical innovation in the system, as compared to a traditional sliding gate, lies in the fact that the entire gate is cantilevered off the ground without any rollers traveling on the ground. This allows for free movement of the gate in uneven ground conditions and reduces the wear and tear on the gate and on any installed gate automation. The sealed bearings on the carriage assembly require no maintenance or lubrication. Besides, it gives the gate a nice clean look with minimal visible hardware. This engineered solution also reduces the length of the counterbalance resulting in a smaller overall gate length.

The bottom track is available in galvanized steel, aluminum track and stainless steel and can accommodate a solution for every type of rolling gate project. By welding or mechanically fastening the gate to the bottom track, Duragates sliding gate system can be used with any gate material such as steel, wood, vinyl, aluminum, chain link, etc.

The model selection depends on the combination of the size of the opening and the weight of the gate. Based on the combination, several models may fit your project. The heavier the model, the smaller the counterbalance (tail of the gate) which becomes increasingly important when you have a tight space. Our cantilever gate configurator will provide you the optimal selection of model along with dimensions of the tail of the gate, the position of the carriages and the foundation size required.

The hardware, combined with a range of high-quality gate automation we offer, is truly a long lasting and complete solution for any cantilever sliding gate. Send us your sliding gate details for a customized gate configuration.

Q: Where do I start?

A: The first step is to think about what kind of gate design and gate material you want. The advantage of using our hardware is that you can use practically any gate design with any gate material. Then, let us know the size of the opening and the approximate weight of just the opening part of the gate. We will then come back to you with the suggested model, overall length of gate including counterbalance and size of the foundation required. Armed with that information you can then complete your gate design.

Q: I have seen most cantilever track with a top track system. What are the advantages of the Duragates system over the top track system?

A: There are several advantages actually.

- First of all, the weight of the gate is transferred to the ground, hence it can bear a lot more load than a top track. Besides there are less chances of the track bending/buckling
- You can use any gate material versus mainly steel/aluminum for the top track system
- You can design any gate shape versus only a straight gate for the top track
- Performs better in the snow
- Looks much better versus the industrial look of the top track system
- Our system needs a smaller counterbalance versus the top track thus reducing the overall gate length
- You don't need an elaborate system of posts to mount the gate to. Posts tend to shift over time causing problems in the future. Our system only needs a top guide plate that can be installed even on masonry columns

Q: Can I use any gate material?

A: Yes, you can use practically any gate material as long as you can mechanically attach the gate to the bottom track. In

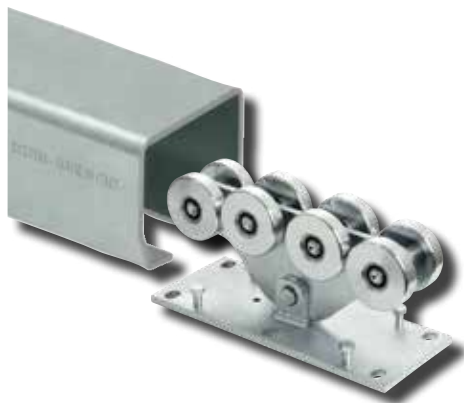

case of a steel or aluminum gate you can just weld the gate to the track, or even use the track itself as the bottom frame of the gate.

Q: The system looks very simple. What am I missing?

A: You are not missing anything ! The system is actually very simple. Just a track, 2 wheels and some related accessories. Not just that, it is also very aesthetically appealing with minimal visible hardware.

Q: I live in very heavy snow conditions. How does it perform in these conditions?

A: The product actually works better in the snow than most traditional sliding gate hardware systems.

- The wheels are always covered with the track, hence you never have to clean the wheels.
- There are no exposed rollers unlike some other cantilever systems
- The path of the gate travel has to be cleared of snow, which would have to be done for any gate
- You may have to adjust the foundation depth based on the frost line in your local area

Q: I don't know the weight of my gate. Where do I go from here?

A: We urge you to at least roughly estimate the weight of the gate based on the materials and design used. It is an important starting point in order for us to help you configure the overall gate dimensions.

Q: My gate is very small. Can I use your system?

A: Absolutely. Our system can be used for openings as small as 2 to 3 ft in residential and even indoor applications. You don't need to pour a foundation for small gates/doors such as these. See our project gallery for examples.

Q: Which gate operator can I use?

A: Our system is totally independent of the gate operator. You can use a gate operator of your choice. In fact the face of the bottom track provides a nice surface to mount the gear rack to (for rack/pinion type operators). The track slides very smoothly on the carriages thereby reducing the load on the operator.

Q: What kind of maintenance does it require?

A: None really. The carriages have sealed bearings. Depending on usage, the bearings may wear out eventually and it is then advisable to replace the entire carriage. If you ever want to service the gate, simply remove the end caps and slide the gate off the track.

Q: How much effort will I need to operate the gate?

A: The track slides very smoothly on the carriages and you can operate the gate with just one hand. Of course, depending on the weight of the gate and the application you may want to install a gate operator. Due to the smooth operation, the load on the operator is also reduced.

Q: Can the gate travel at an incline?

A: Unfortunately that is one application where the gate won't work. The carriages have to be installed horizontally and in one line. However, since it is cantilevered off the ground, the ground itself can be at an incline. You just have to install the gate high enough to clear the highest point on the ground.

Q: Can I install the carriages on a post instead of on the ground?

A: We highly discourage installing the carriages on the post as it will not be able to bear a high load and will also cause problems once the post starts to shift. In fact the system is designed to avoid all the problems associated with mounting the carriages to a post. We realize that there is an added cost involved in making a foundation. However, for light duty applications, many of our customers have been able to post mount the carriages or not pour a foundation. Once you understand how the system works, please use your judgment to determine what could work in your application.

Q: I have an arch top on my gate. What do I use for the top guide?

A: For arched and other gate shapes we recommend using the monorail CG-254 and the roller CG-252. This galvanized steel monorail can be installed horizontally somewhere along the full length of the gate and will provide adequate support.

Duragates.com

MATERIAL OF GATE OR GATE FRAME

The following information is required to make sure the hardware selected for the gate will be sized correctly to carry the load and give an expected long service life.

With this system, the gate infill can be of any material as long as you can attach it to the bottom track. Some common combinations are as follows.

Steel Gates that weld or bolt directly to steel track

- Chain Link
- Ornamental Steel
- Wood gates on a welded steel frame
- Wood framed gates

Aluminum Gates that weld or bolt directly to aluminum track

- Ornamental Aluminum
- PVC gate on an aluminum frame
- Wood gate on an aluminum frame

Stainless Steel Gates that weld or bolt directly to stainless steel track

- Stainless Steel Gates
- Unique and/or exotic metal gates

PVC Gates These gates need to have a metal frame for structural support.

Aluminum or stainless is compatible with PVC, but we do not recommend galvanized steel track for PVC gates because of accelerated corrosion issues. If the galvanized steel is separated by some sort of a barrier (i.e. (rubber, plastic, stainless) material, the corrosion process may be slowed down.

WIDTH OF THE OPENING

This is typically the width of the driveway, dimension "L", in the image below.

NOTES:

If the gate is required to travel more than 4 inches past the opening (the "closed" position), then this extra distance should be added to (L) opening size.

If the foundation pad will need to be set back farther than 9" away from the opening for any reason, then this extra distance should be added to (L) opening size. Reasons could include "something" in the ground (pipes, conduit/electrical, drainage, etc.), an obstruction, or could be for aesthetic reasons.

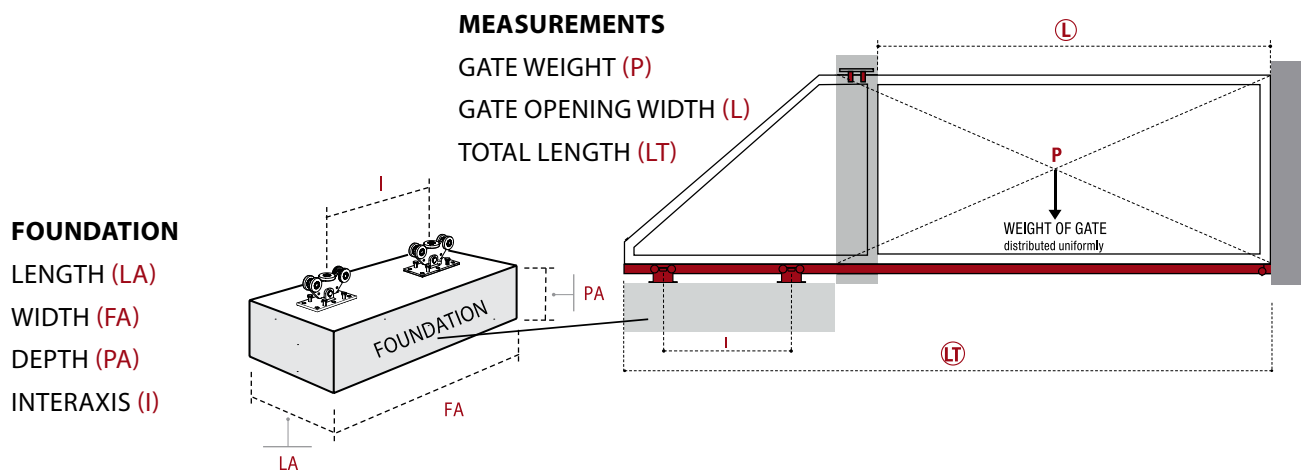

WEIGHT OF THE GATE

When we estimate the weight, we typically are thinking of, and include the full length of the gate assuming a 50% tail section.

However, for our purposes, this is the estimated or calculated ***weight of the gate for the portion that spans over the opening length (L)*** and does not include the tail section. Clarify if possible, how the weight was determined. *The weight of the cantilever track need NOT be included in the gate weight estimate (P).*

Note: Most fence installers and fabricators tend to overestimate the gate weight.

The chart below shows typical per foot weights of common gates.

Gate Type and material	Typical Range	Average
Steel Picket Gate, Residential, 6 Ft high	20 - 40 lbs/ft	30 lbs/ft
Steel Security Gate, Heavier Duty	40 - 120 lbs/ft	50 lbs/ft
Aluminum Picket Gate, 6 Ft high	10 - 30 lbs/ft	15 lbs/ft
Wood Gate with Cedar planks full privacy, 6 Ft high	20 - 30 lbs/ft	25 lbs/ft
Wood Gate with Steel frame	20 - 40 lbs/ft	30 lbs/ft
Wood Gate with Aluminum Frame	15 - 30 lbs/ft	23 lbs/ft
PVC/Vinyl Privacy Gate, 6 Ft high	15 - 20 lbs/ft	17 lbs/ft
Chain Link Gate, Residential, 6 Ft high	8 - 12 lbs/ft	10 lbs/ft
Chain Link Gate, Commercial, 6 + 1, w/barbed wire	15 - 25 lbs/ft	18 lbs/ft

TAIL LENGTH AND CARRIAGE SELECTION

The Duragates system allows for a shorter tail length than the typical 50% for other types of cantilever hardware. However, there is often a tradeoff between the length of the tail section and the size of the cantilever hardware. Choosing a larger carriage will usually result in a shorter tail section.

Some other factors that affect the optimal tail length are as follows:

- If there is a space limitation you may need to upgrade to heavier hardware.
- The physical gate may already be built to a certain overall length (LT) and the track is to be fitted to the existing gate.
- For aesthetic reasons or other, it may be desirable to build the gate longer than specified.
- While extending the tail section does not change either the gate opening (L) or weight (P) parameters, it does change the “effective” opening size for the gate when the gate is in the “full open” position. More weight and length are being cantilevered in this open position than the configurator accounted for in its design.
- It is recommended that you extend both the length of the concrete pad (FA) and the carriage spacing (I) by the same distance that you extend the gate length (LT).



The carriage selection also depends on the application and frequency of use.

Residential

- Smaller, less expensive hardware is typically desirable

Multi-Family and Commercial

- Space limitations more likely
- Higher usage may warrant upgrade in size

Industrial

- Heavy duty hardware typically preferred
- Typically have high cycle rates, so heavy duty hardware extends gate life

ALTERNATE CARRIAGE MOUNTING OPTIONS

We recommend mounting cantilever hardware on a single pad that has been poured into the ground and extends down past the frost line. This ties the two carriages together on one solid foundation for permanent alignment and significantly reduces independent movement of the carriages.

Other options for installing carriages are post mounted and pier mounted, and if done properly, it will not significantly impact the performance, although it may shorten the service life of the gate.

When using either of these alternate carriage installations keep in mind that Duragates hardware allows for shorter total gate lengths by using the weight of the concrete foundation as part of the counterweight. With post or pier mounted carriages, you need enough concrete in the ground to support the loads pushing down on one carriage AND the loads pulling up on the other. Depending on the weight and opening size, you will need piers or post holes that are 16" to 24" in diameter and deep enough that together they hold the same volume of concrete as required for pad mounted carriages.

Post Mount Installation Suggestions

- Position the "front" carriage on the end post at the opening, or on a post within 10 inches of the opening. NOTE: If the end post is used to mount the carriage, the gate will protrude into the opening a few inches when in the fully open position.
- Position the "back" carriage at the position specified by the configuration to match the carriage spacing (l). It is ok to extend the carriage mounting position back (longer) to the next post if desired, but you must follow the guidelines for "Extending the tail length of the gate". It is NOT ACCEPTABLE to reduce the carriage spacing to match up with a line post.
- Dig the holes and pour concrete equal to the volume specified by the configuration. Make the holes big enough to accommodate the concrete necessary to carry the load of the cantilevered gate.
- Confirm that the hole depth is below the frost line.
- We recommend connecting the two carriage support posts mechanically by welding or bolting a horizontal member at or just below ground level. This keeps the two carriages from moving independently and misaligning over time.
- Mount the carriages on the post mount bracket making sure 1) the orientation is correct; and 2) the carriages are level and plumb, and also level with each other as described in the installation instructions section "Set the Carriages".



Pier Mount Installation Suggestions

- Position the "front" pier just behind the end post at the opening so the carriage can set 9 inches behind the post.
- Position the "back" pier at the position specified by the configuration to match the carriage spacing (l).
- Dig the holes and pour concrete equal to the volume specified by the configuration. Make the holes big enough to accommodate the concrete necessary to carry the load of the cantilevered gate.
- Confirm that the hole depth is below the frost line.
- Mount the carriages on the piers making sure 1) the orientation is correct; and 2) the carriages are level and plumb, and also level with each other as described in the installation instructions section "Set the Carriages".

Pier mount example

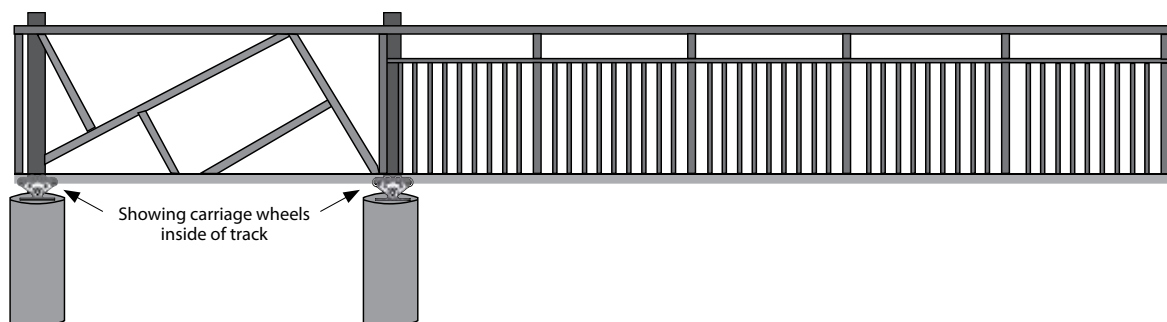

ACCESSORY SELECTION

CG-348 - J-Bolts set into newly poured concrete are the best method of anchoring the carriages to the pad.



Mini and Small Carriages (M) require 4 J-Bolts per carriage.

Large (P), Grande (G) & Extra Large (XL) Carriages require 6 J-Bolts per carriage

CG-05 - Foundation Plates make it easier to level and align the carriages, but are not required.



CGS-347 - End wheels serve three functions:



- 1) covering the end of the track for UL325 compliance when the gate is automated,
- 2) assisting the gate to seat effortlessly into the end cup receiver to stabilize the gate in the open and closed positions, and
- 3) keep dirt and debris out of the track for smoother operation.

CGS-346 -End cups are used to stabilize the gate in the fully open and closed positions AND to provide a positive gate stop to meet safety code for automated gates. Typically 2 are used per gate. For gates that stay closed most of the time only 1 is needed.



CG-15 - Heavy duty adjustable "L" bracket to mount end cups and receivers to the side of the fence post or column.



CG-30 - Slide gate receiver should be positioned near the top of the gate on the receiving post or column. The size of this guide receiver is matched with the gate frame, and not the track model.



- CG-30M - Fits 2" to 3" frames
- CG-30P - Fits 3 3/8" to 4 1/2" frames
- CG-30G - Fits 4" to 6" frames

CGI-40 - The tension bar is a stainless steel turnbuckle and fits 50mm metric tubing, USA 2-1/2" sq. min. (shimmed). The tension bar provides the easiest way to adjust the gate over time. It is especially recommended for double gates to simplify aligning the tops of the gates where they meet in the center, and for gates longer than 40 feet where gate sag becomes exaggerated.

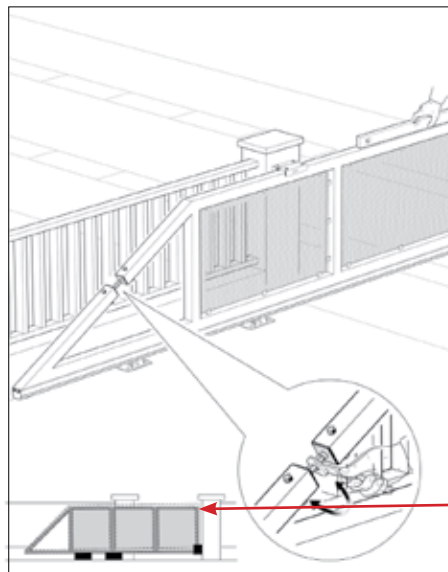
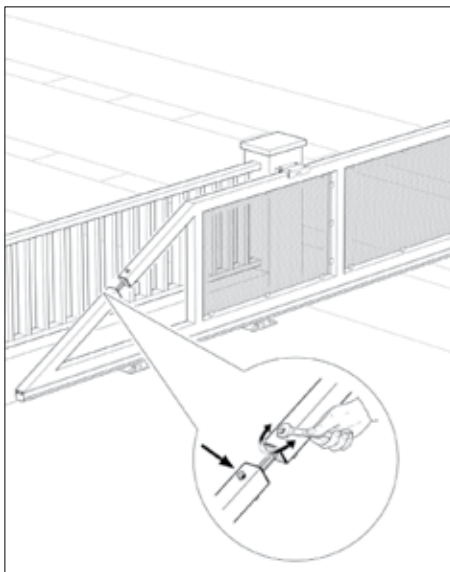

The top corner of the gate will rise and fall as tension is adjusted on the tension bar.

GATE TOP GUIDE SELECTION

Guide assembly choice primarily depends on how the top of the gate is built. For over the top guides, a flat, even surface is necessary for the rollers to run on. For gates built without a flat top, side rollers or monorail guides are necessary.

Typically, only one top guide assembly is needed, but for gates with 26 ft or larger openings or for privacy gates with significant infill, we recommend two top guides spaced apart approximately by the same distance of the carriages.

The monorail guide with 2 guide rollers is recommended for ice and snow conditions. This gives a fully covered track and a very small area for the gate to freeze to the guide.

Top Guides (over the top style)

- Require smooth surface on both sides of the gate
- Flat top gates
- Wood privacy gates



255-220-C
For up to 2¾" frame



256-220
For up to 3" frames

256-300
For up to 4½" frames

Side Rollers

- Guide post is required on both sides of the gate
- Requires smooth surface on both sides
- Arched top gates (match the arch height)
- Picket top gates
- Security gates with razor or barbed wire
- Wood privacy gates
- Face mounted picket gates



253
10" Side Roller
1¼" dia.
2" clearance
Use 2 per gate min.

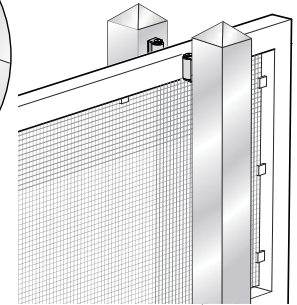
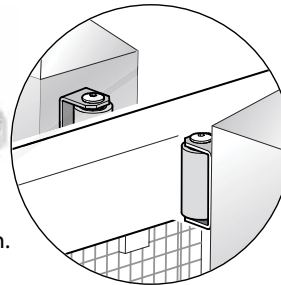

CGS-499
1100 lb load capacity
guide roller
(use in pairs)

Monorail Guide with roller

- Arched top gates
- Picket top gates
- Chain Link Gates
- Wood Picket gates
- Face mounted picket gates
- Security gates with razor or barbed wire
- Aesthetic/design to hide guide assembly

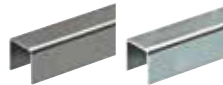

CG-254
Galvanized 1½" U-Channel
Use guide rollers CG-252 or 258-30

RG-387
Galvanized 1¼" U-Channel
Use guide rollers 258-30

CG-237
Aluminum 1½" U-Channel
Use guide rollers 258-30



CG-252
Single Roller
1½" dia.



258-30
Double Roller
1¼" dia.

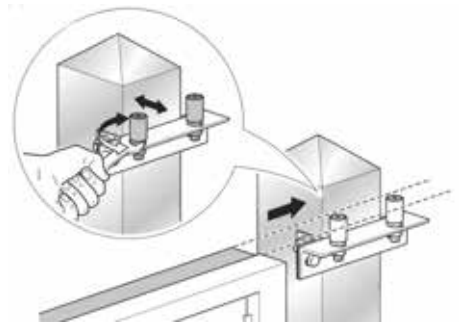

GATE SAFETY CODE CONSIDERATIONS

Manual gates do not require specific accessories or design considerations to meet code. But automated gates can cause serious injury or death. There are two sets of safety codes to guide installers and manufacturers in delivering safe gates to the marketplace.

Make sure your gate system is installed and maintained according to the manufacturer's installation instructions. Make sure your installer adheres to UL325 and ASTM F2200 standards.

DO - Operate your gate system only when all necessary entrapment protection devices are connected and working properly.

Examples of these devices include:

- Sensing edges
- Photoelectric sensors (e.g. photo eyes)

Follow ASTM F2200 standard for automated gates. Where applicable, these include the following:

- Covers for all exposed weight bearing rollers and pinch points that exist less than 8 feet (2.5 m) above grade.
- Fallover protection to prevent the gate from falling when gate is detached from supporting hardware.
- Physical gate stops to avoid over-travel in both directions.
- Proper adjustment of the inherent sensing system.
- No protrusions along the bottom of the gate.
- Protective screen mesh to guard openings from the gate's base support to a minimum height of 6 feet (1.8 m) above the ground. This must prevent a sphere of 2¼ inches (57 mm) from passing under or through any opening in the gate or adjacent fence (the portion covered in the gate's open position.) Refer to the illustrations.

PRECAUTIONS FOR GATE SYSTEMS

ENTRAPMENT ZONE HAZARDS

Body parts may become entrapped between a gate and a stationary object when the gate begins to move, which can result in serious injury or death. **Make sure pedestrians stay clear of the gate path and areas where gate motion is close to stationary objects.**

PINCH POINT HAZARDS

- In open roller slide gates, severe injury can occur when hands and fingers get caught in the slide gate rollers. Feet can be injured between the bottom of the gate and bottom rollers. **Make sure roller guards are installed to cover these pinch points.**
- A swing gate's opening mechanism may have arms that can overlap with a scissoring effect, which can result in serious injury. **Make sure pedestrians stay clear of the gate path and the opening mechanism, especially when the gate is in motion.**

CRUSH HAZARDS

In picket gates, body parts positioned between the bars can become seriously mutilated when the gate begins to move, which can result in serious injury or death.

Make sure openings are covered or screened and gaps are filled to prevent persons from reaching through, and/or passing through, the gate.

HORIZONTAL SLIDE GATE SYSTEM

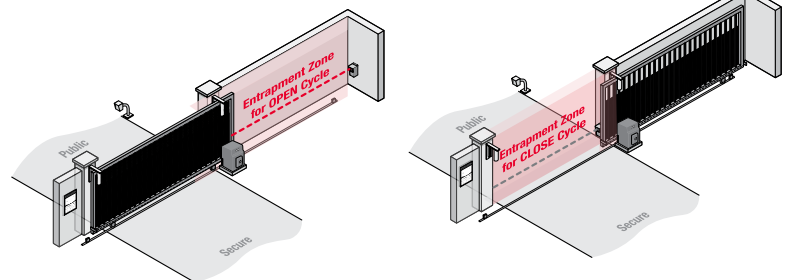

MORE INFORMATION

Websites:

DASMA: www.dasma.com

Underwriters Laboratories: www.ul.com

Automated Vehicular Gate Standards,
ASTM F2200: www.astm.org

STEP 1 - PREPARATION OF THE FOUNDATION

Prepare the foundation site and pour as per the measurements received in your configuration sheet. Best practices call for the concrete depth to be below the frost line, so we recommend digging the foundation deep enough to extend below the frost line at the installation site.

Call
908-757-2323
or request a quote at
Duragates.com to
get your gate
configured
using our online
calculator.

NOTE: We recommend using reinforced concrete with specified gravity of a minimum of 1.56 lbs/cu ft.

Concrete Pad Considerations

The online configurator calculates the concrete pad dimensions based on the gate opening size (L) and gate weight (P). The pad acts as the counterbalance weight for the gate, allowing for shorter tail sections.

NOTES:

- The pad length is nearly the size of the gate's tail length (ca. 95%).
- The pad dimensions (FAxLxPA) do not take the frost line into consideration and the pad must be deeper than the frost line to prevent frost heaves that may displace the pad.
- The pad dimensions determine the volume of concrete required to provide a counterweight. Any alteration to the length, width or depth of the pad must NOT reduce the volume.
- The pad will often extend under the fence line. This will allow the gate to be placed close enough to the fence line to meet the UL325 entrapment code spacing of $2-1/4''$. Distance "A" in the figure on page 11 should be chosen so the edge of the fence is less than $2-1/4''$ from the edge of the end post or column at the opening.
- The leading edge of the foundation pad should start 5" from the driveway opening

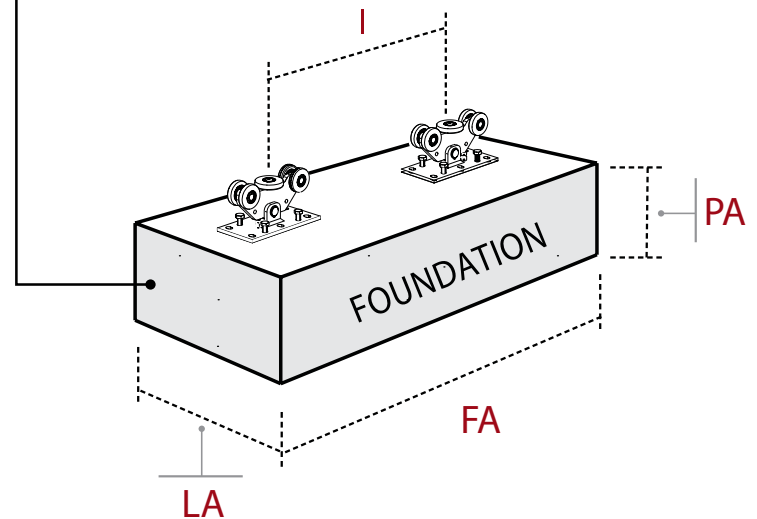
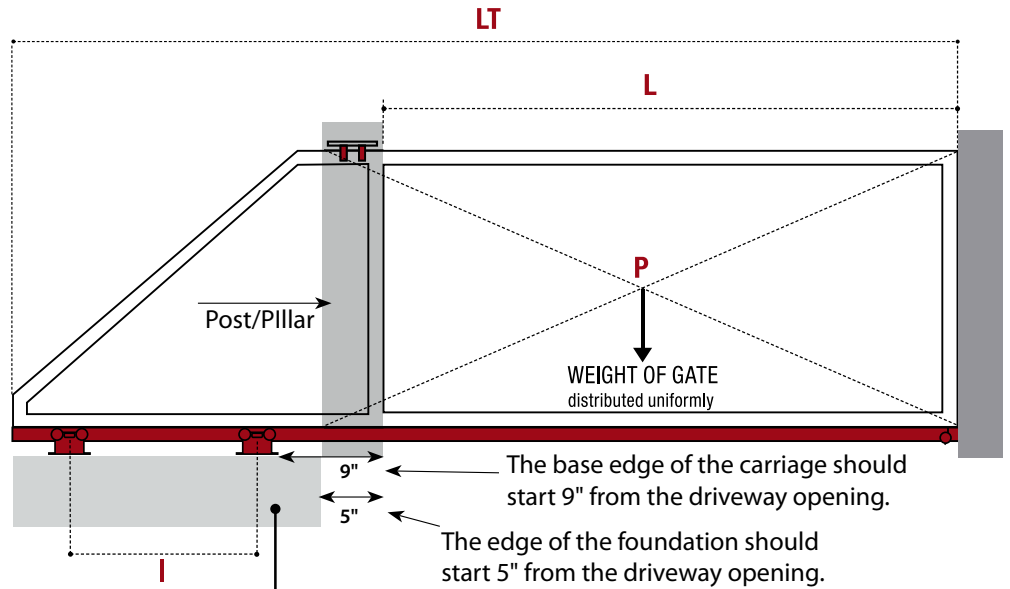

STEP 2 - J-BOLT / TIE ROD INSTALLATION

Once the foundation is prepared, fill the hole with concrete and level to top. Sink or hang the J-Bolts so they are centered "end to end" on the pad, with the leading edge of the front carriage a minimum of 5" from the edge of the concrete. Be sure the center-to-center distance between the carriages is as specified as dimension "I" on the configuration sheet.

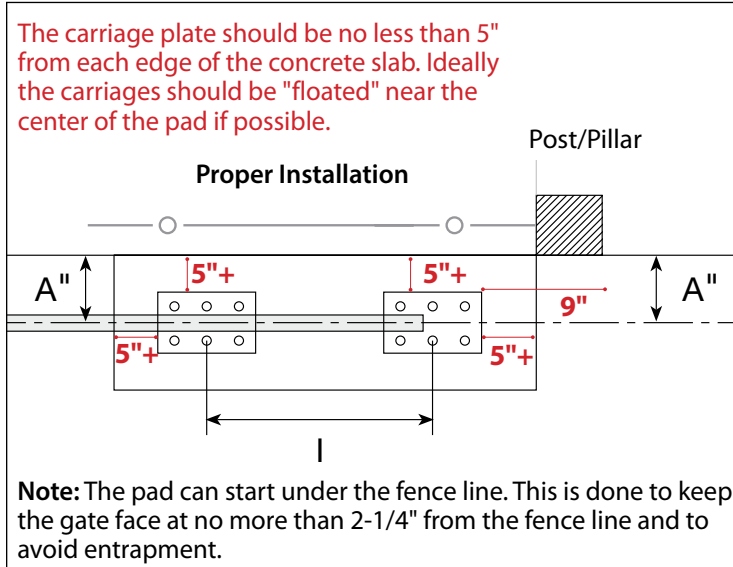
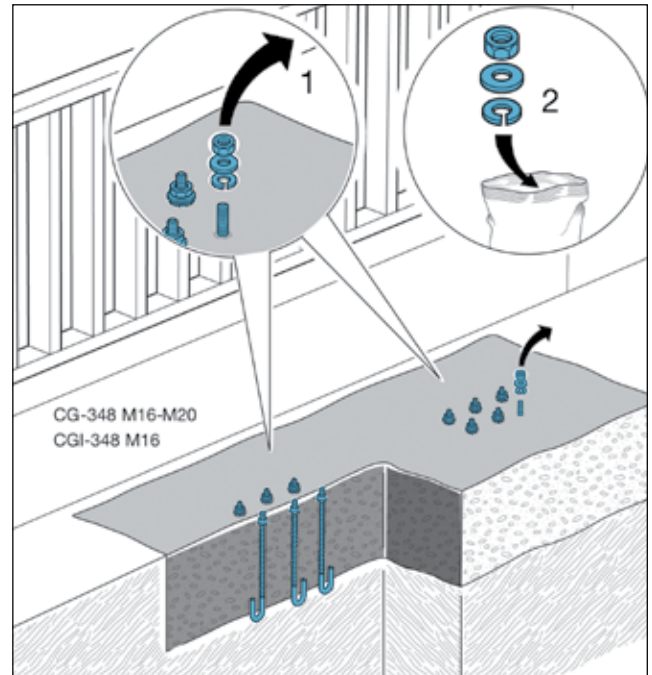

Wrong Installations

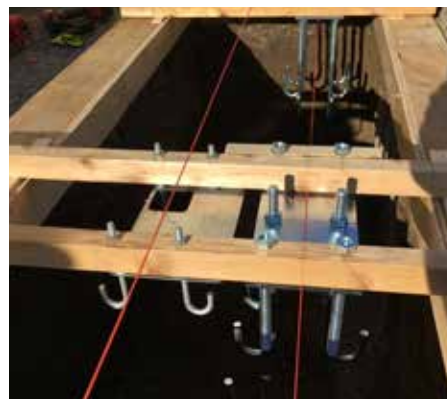
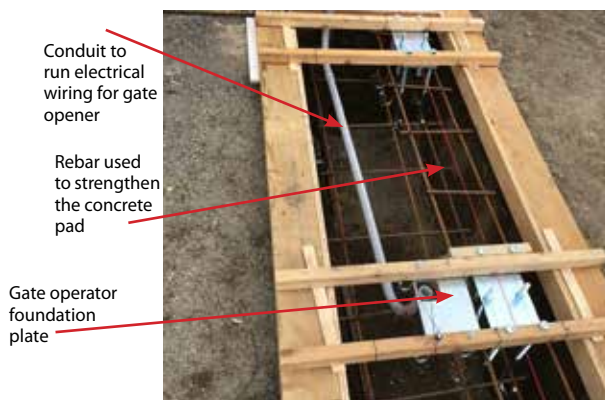
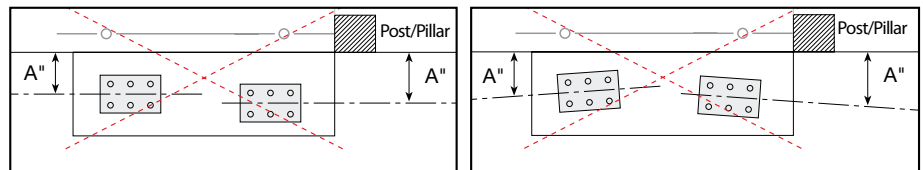

Line up the bolts. Use a string line, template, or other means to ensure bolts are correctly spaced apart per the (I) dimension from the configuration. Line up with the other carriage and run parallel to the gate opening.

Run a string line or laser across the opening to ensure the gate lands at the right point when closed.

Note: The top of the bolt/tie rod should stick out of the cement at least 2". When using a temporary template to set the J-bolts the bottom nut may be sacrificed into the concrete.

STEP 3 - SET THE CARRIAGES

Once the foundation is well hardened, loosen the nuts off the J-Bolts, clean and level the area where the foundation plates or carriages will rest to prepare for the installation of the carriages.

Place the Foundation plates over the J-bolts.

Make sure the orientation of the carriage is correct.

Use the flat and lock washers to secure the carriage to the bolts.

Align and level the carriages, then begin tightening the nuts,

constantly checking that the carriages are level. If they are not level, then adjust the carriage to level, and also level with each other.

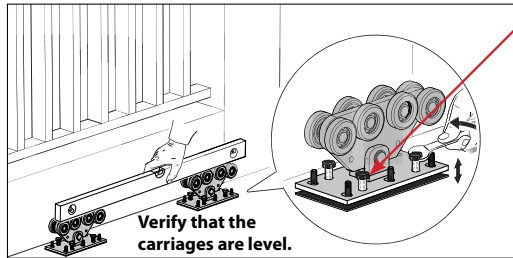
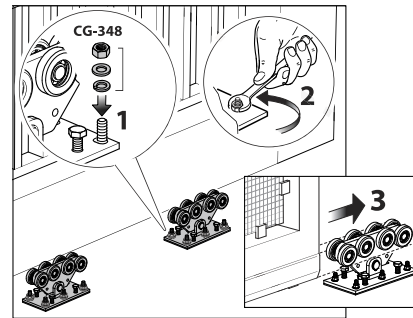
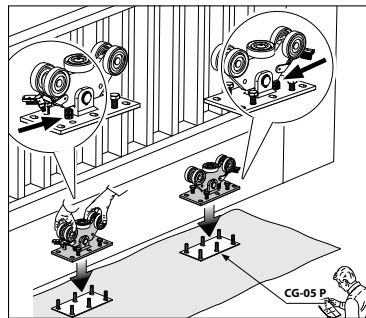
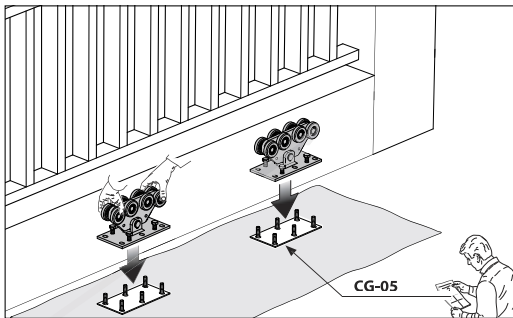
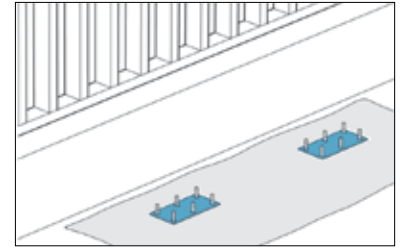
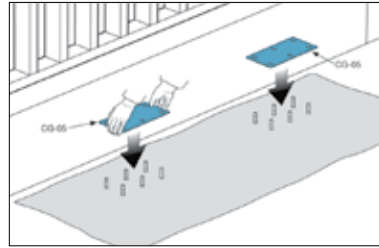

Vertical adjustment jackbolts are available on the "P" & "G" carriage models. They are not available on the "M" carriages.

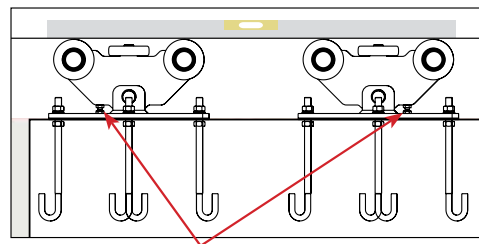

Note: When mounting the CGA carriages, make sure the regulating screws are facing towards the outside as shown in the picture.

If not using foundation plates

Option 1: Carriages will sit on the bottom nuts on the J-bolts to allow plumb/level adjustments using the J-bolts as jack bolts

Option 2: Carriages can be placed directly on the foundation. Plumb/level adjustments must be done by shimming the carriages.

NOTES:

- For Piccolo carriages, the regulating screws should face "outward" and not be installed between the carriages, and for the aluminum P carriage, the sweep brush should also be on the "outside".

Using the CG-05P Foundation Plates with "M" Carriages

The foundation plate has 6 holes, but the "M" carriages only have 4 mounting holes that align with the middle holes and one side of the outside holes as shown.

The diagrams to the right show how to use the CG-05P foundation plates with the CGS-250.8M & CGA-350.5M carriages.

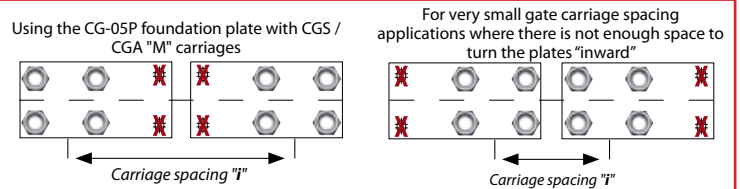

- For carriage installations using the J-bolt as the jack bolt adjustment method, it is best to back fill the space under the carriage with grout to keep the carriage firmly secure over time. This is especially true for heavier gates.

Grout and fill the space under the carriage.



The nut below the carriage can also be used for adjustment.

STEP 4 - ATTACHING THE GATE TO THE TRACK

Attach your gate to the top of the track by welding or mechanically fastening.

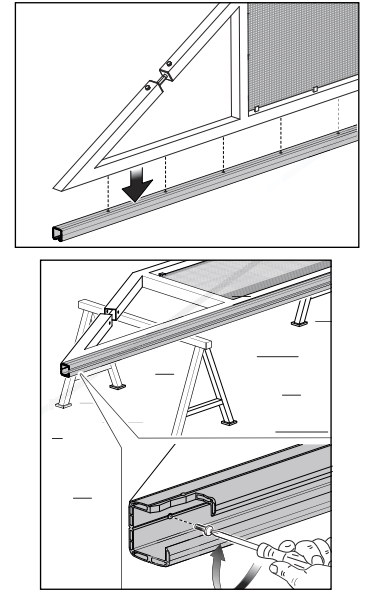
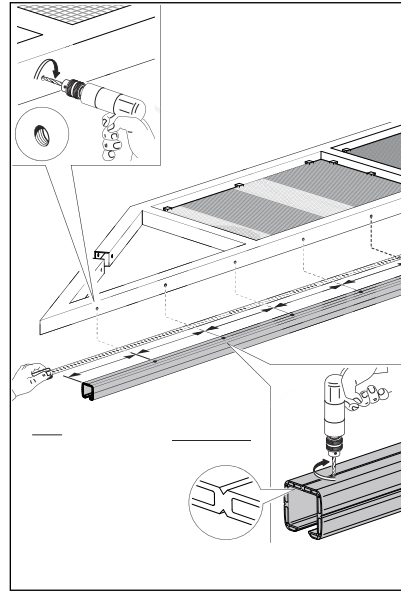
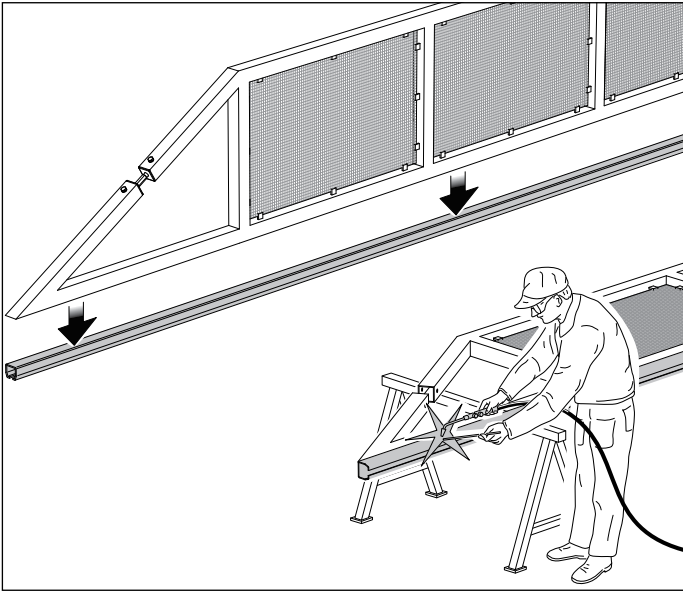

When the gate frame material and the track material are different, you have a few different options. For example, a wood gate on a steel track, a PVC gate on an aluminum track, or an aluminum gate on a steel track.

- 1) Bolt/screw on the gate frame to the track - drill up and thru the top of the cantilever track and bolt the frame to the track. Caution - it's best to use counter sinking bolts/screws so that nothing protrudes into the track cavity to obstruct the carriage wheels. There is a gap in the middle of the wheels on the carriage where a hex head bolt will fit between and not obstruct gate travel, but you must be very careful in size selection and placement.
- 2) Weld small tabs with bolt holes along both edges of the track (like alligator skin). Bolt thru the gate frame and tabs.
- 3) Use a length of flat bar or angle along the bottom length on both sides of the gate frame. Weld this flat bar or angle to the top of the cantilever track and bolt through the gate.

Welding the gate to the track

We recommend stitch welding both sides down the length of the track and gate frame as shown below.



STEP 5 - INSTALL THE END WHEELS

Install the end wheels into both ends of the track. These are recommended to help keep dirt and debris from the inside of the track and for UL-325 compliance. By themselves, they are not a positive stop.

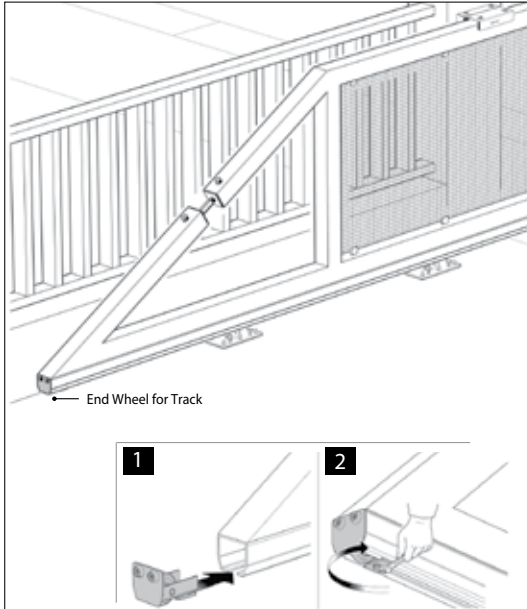

STEP 6 - INSTALL THE MOUNTING BRACKETS

The adjustable mounting brackets are used to hold the bottom end cup.

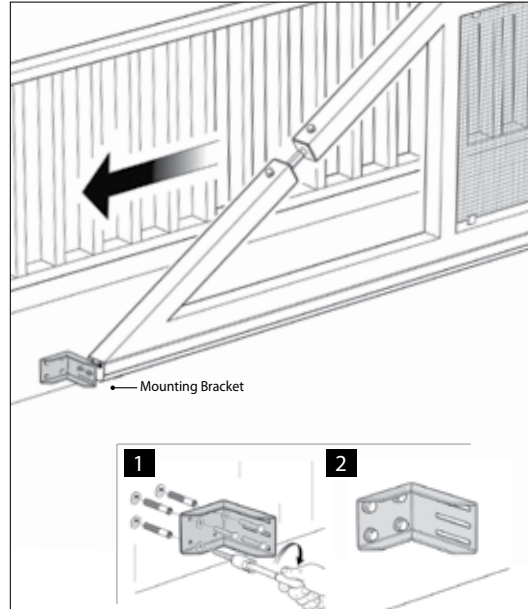

STEP 7 - INSTALL BOTTOM END CUPS TO THE MOUNTING BRACKET

Install the bottom end cups to the adjustable mounting bracket. The bottom end cups provide a positive stop for the gate and eliminate vibration in the gate, extending the life of the carriages.

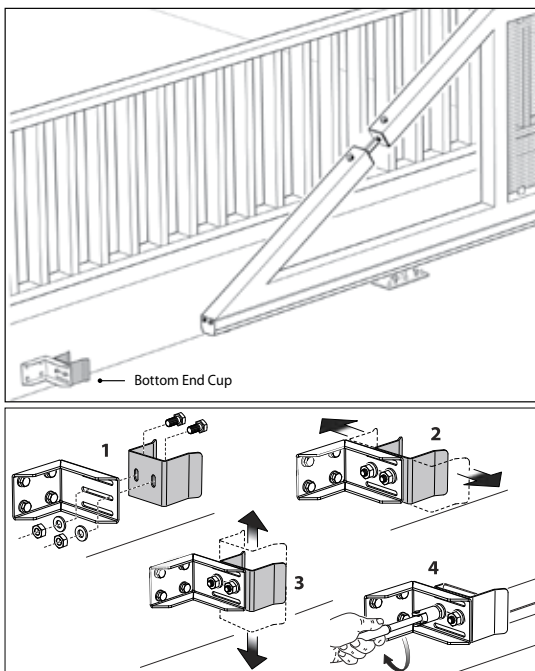

STEP 8 - INSTALL THE GATE RECEIVER

The gate receiver can be installed on the closed side of the gate to keep the gate steady at the top. Install the gate receiver to a mounting bracket.

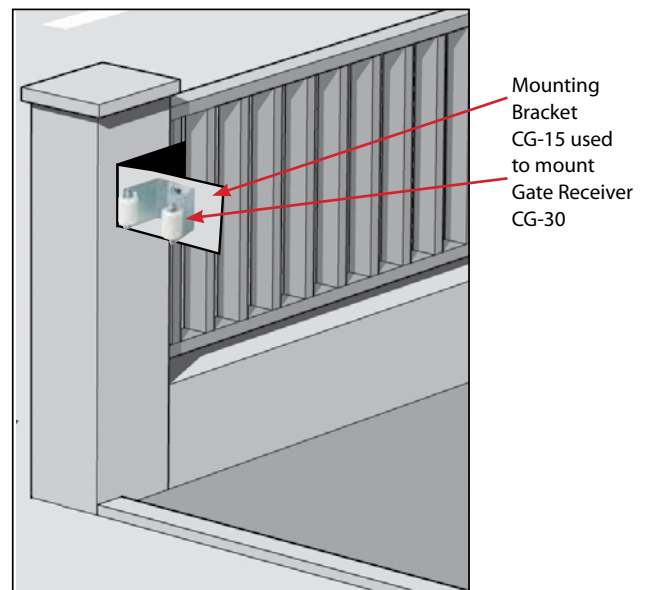

STEP 9 - INSTALL THE TOP GATE GUIDE

The top gate guide is installed on the post near the carriages. The top gate guide keeps the gate vertical under wind loads, but does not support the gate load. For gates longer than 25 feet we recommend using 2 top guides.

Over the top styles: 255-220-C, 256-220 or 256-300

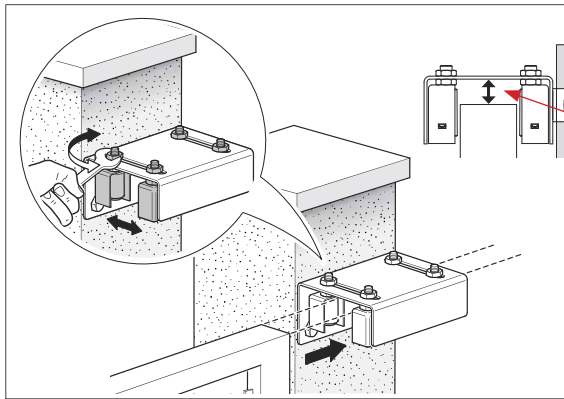

Top clearance dimension is approx 1/8".

See page 8 on choosing a top guide.

If the gate has an arched or decorative top, then the U-channel would be used for a side mount, upper guide option. This style allows for a "hidden" guide and the rollers will not mark the surface of the gate over time. A single roller and a double roller option are available. The U-Channel should be installed at least half way up from the bottom of the gate and above the center of mass of the gate.

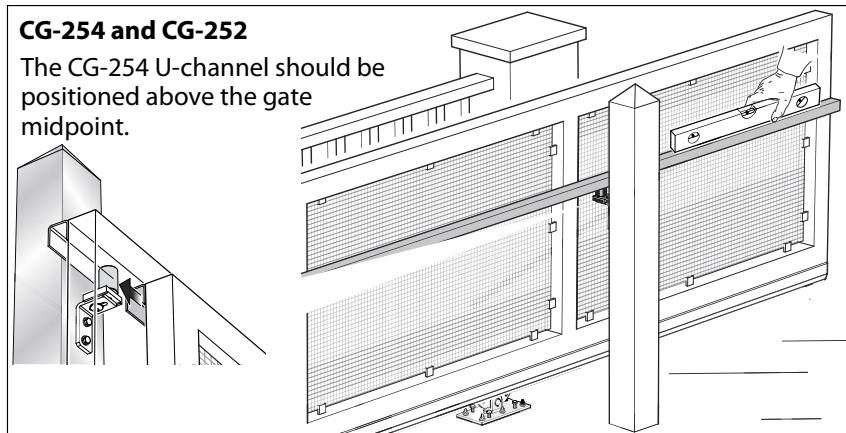

If the U-channel is not an option, then the 10" nylon rollers could be used to support the gate. A post would have to be set on both sides of the gate and a minimum of 2 rollers are needed on each side.

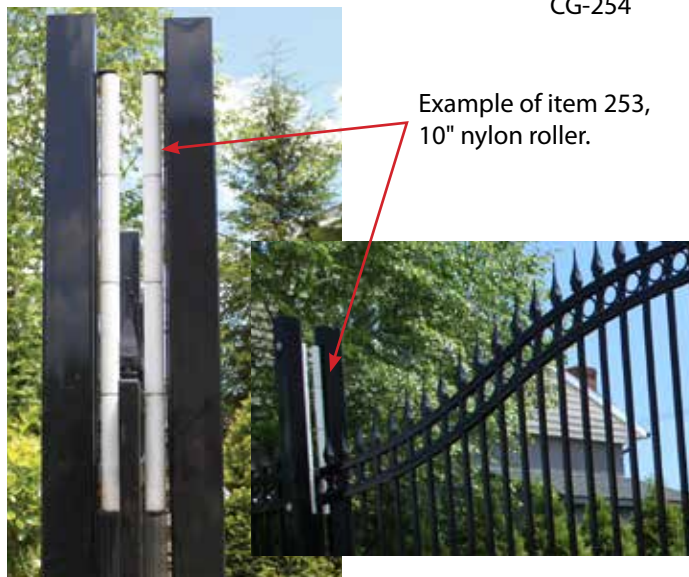

GATE TRUSSING FOR SELF-SUPPORTING GATES

All cantilever gates must be manufactured and trussed in a way that they are self-supporting. The Duragates track is built to support the weight and balance of the gate but will not support gates that are not trussed to prevent sagging or curling, or are not in and of themselves self-supporting.



Diagonal trussing in the vertical dimension is needed for all gates. A simple diagonal in the tail section will work for many "smaller" gates.



Diagonal bracing in each section should be used for large gates with a 30 ft or greater opening.



Long gates also need lateral trussing to resist wind and the tendency to "lean over" to one side. Often referred to as a "strong arm" support, this is a 1 ft wide "panel" attached perpendicular to the gate, running the full length of the gate. This is especially important for privacy style gates, or any gate with significant infill to catch the wind.



Example of a wooden gate with aluminum frame, well trussed and supported.

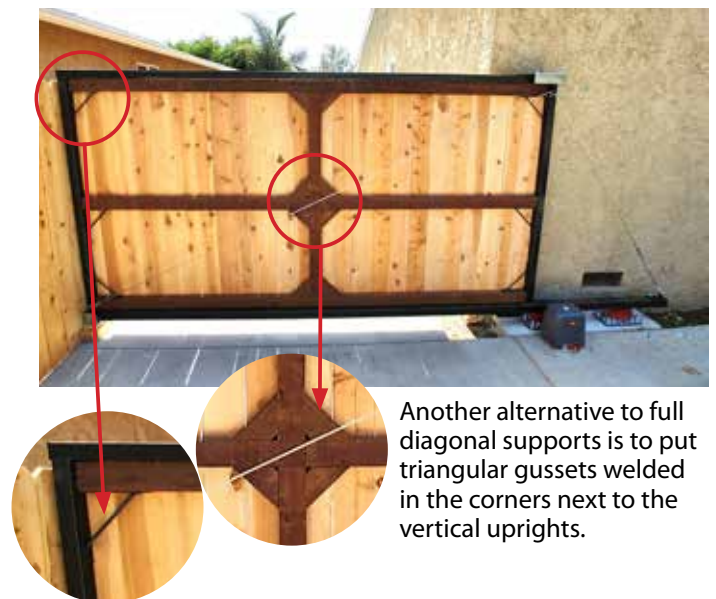

Another alternative to full diagonal supports is to put triangular gussets welded in the corners next to the vertical uprights.

USING THE BOTTOM TRACK AS PART OF THE GATE FRAME

The Duragates track can be used as the bottom horizontal rail of the gate. This allows for some material savings and a sleeker look as the track becomes part of the gate itself.

This works well for light gates with a high percentage of air flow through the gate. Both aluminum or steel gates that are picket style, use chain link or wire mesh as infill are great applications for using the track as the bottom rail.

The exceptions to consider are:

- In high wind environments when excessive side load is expected
- For heavy commercial gates
- On gates with openings longer than 28 feet wide

Some fabricators prefer not to use the track as the frame because it is usually wider than the rest of the gate frame, so laying it out on the table takes more time.

WELDING BOTTOM TRACK TOGETHER FOR LONGER GATES

When connecting two or more pieces of track, butt welding the ends together works well when the gate has a bottom horizontal rail as part of the gate frame. When the bottom track itself is part of the gate frame, a 45-degree splice is better in order to distribute the stress points along the width of the track.

It is always best to splice the track in a position where the gate does not stop fully open or close with a carriage directly over the splice. When the splice is directly over a carriage you should use the 45-degree splice.

For steel, bevel the outside and weld the outside perimeter of the splice. It's best not to weld inside of the track because it creates an exaggerated bump in the travel and is quite difficult to grind and clean up. For aluminum, the track is a hollow complex profile, so there is not enough material to bevel the track before welding.

EXTENDING THE TAIL SECTION OF THE GATE

For a given weight and size of opening, our online gate configurator suggests a minimum length of tail to carry the load. (typically, 30% to 40% of the width of the opening). At times it is desirable to make the tail section longer for aesthetics or to reduce the load on the carriages.

There are three critical dimensions to consider when extending the length:

- The total gate length, LT
- The carriage interaxis spacing, I
- The foundation length, FA

When you increase the overall gate length LT to extend the length of the tail, you need to increase the other two dimensions by the same amount to make sure you do not create an overload situation when the gate is fully open.



MAINTENANCE SCHEDULE

The Duragates system is very low maintenance. The bearings on the wheels are maintenance free sealed bearings and do not need to be lubricated over their lifespan.

No lubricant should be introduced into the track, wheels, carriages, or in the bottom load bearing track assembly. Lubricants and oil based products will attract and build up dust, dirt and other materials that will significantly degrade the performance of the hardware, and shorten it's lifespan.

Maintenance Frequency

The maintenance frequency depends on the application and number of gate cycles.

General Recommendations

Private home or business	Every 2 years
Multi-family < 4 units	Every 2 years
Warehouse	Every 1 year
Multi-family > 4 units	Every 6 months

If the gate is automated, please follow the maintenance schedule for the operator as per the manufacturers recommendations.

Required Maintenance

Carriage/Track

Check the functionality and integrity of the carriages.

Clean the lower area of contact between the wheels and the track.

Confirm that the mounting bolts securing the carriages to the foundation are tight.

Confirm that the fasteners on the End Wheel are secure.

Top Guide Assembly

Check the rollers for wear.

Confirm that the fasteners on the rollers are secure.

Check the condition of the roller covers if applicable.

Gate Stops

Confirm that the fasteners on the End Cups and brackets are secure.

Confirm that the fasteners on the Gate Receiver and bracket are secure.

Warranty

All products have a 2 year warranty. This warranty is limited to the repair or replacement of product parts that FRATELLI COMUNELLO SPA acknowledges as defective. The warranty does not include the costs necessary for repairing or replacing the material (e.g. labor costs, rental of equipment etc.).